

## PRODUCT SPECIFICATION

**ITEM CODE: AQF-BB-TWIN-2**

**2 STAGE AQF BIG BLUE 10" / 20"  
FILTRATION SYSTEM WITH STAND**

**1st/2nd STAGE:  
AQF-BB 10" / 20" OPAQUE HOUSING**

**2STAGE FOOT BRACKET**

**IN/OUTLET: 1" NPT**

**FLOW RATE: 10": 8GPM / 20": 8GPM**

**MAX. PRESSURE: 100PSI**

**MAX. TEMPERATURE: 120° F (50° C)**



**2 STAGE STAND BRACKET**

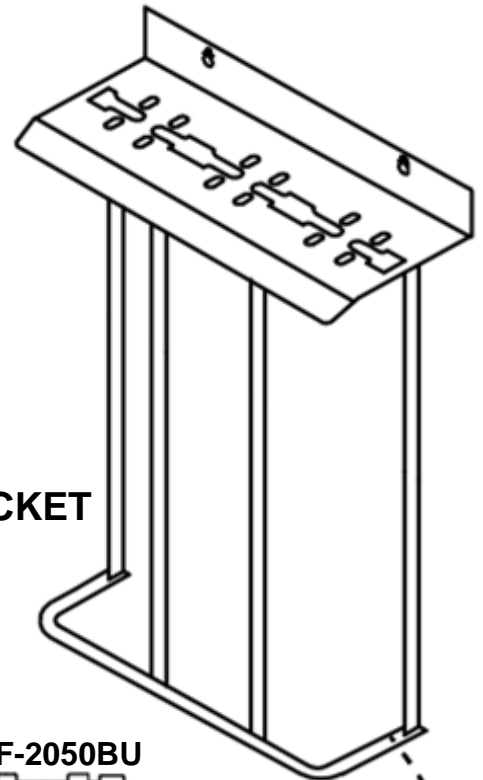

**AQF-2050BU**

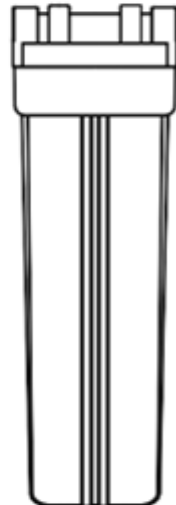

**AQF-1050BU**

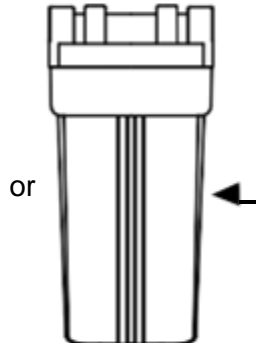

or

**AQF-2050BU**



**AQF-1050BU**

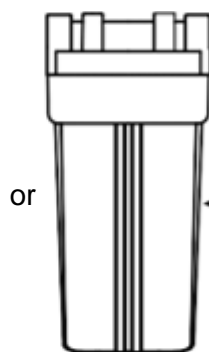

or

**SOURCE  
WATER**

**APC-2045 APC-1045  
CARBON BLOCK CARTRIDGE**

**PPS-2045 PPS-1045  
NSF SEDIMENT CARTRIDGE**

## MAIN PARTS:

1. AQF-1050 NSF BIG BLUE FILTER HOUSING, OPAQUE, 1" NPT IN/OUTLET  
AQF-2050 NSF BIG BLUE FILTER HOUSING, OPAQUE, 1" NPT IN/OUTLET
2. FL-PPS-1045 NSF Sediment Filter  
FL-PPS-2045 NSF Sediment Filter
3. APC-1045 Carbon Block Filter  
APC-2045 Carbon Block Filter
4. BK-2BB-STAND-10 / 20 Coated Metal Bracket
5. WRS-BB Wrench for AQF big blue housing

## NSF International

RECOGNIZES

Aquapro Industrial Co., Ltd.  
Facility: Nantou County, Taiwan

AS COMPLYING WITH NSF/ANSI 42 AND ALL APPLICABLE REQUIREMENTS.  
PRODUCTS APPEARING IN THE NSF OFFICIAL LISTING ARE  
AUTHORIZED TO BEAR THE NSF MARK.



This certificate is the property of NSF International and must be returned upon request. For the most current and complete information, please access NSF's website ([www.nsf.org](http://www.nsf.org)).

A handwritten signature in black ink, appearing to read "Richard Andrew".

August 10, 2012  
Certificate# C0091259 - 02

Richard Andrew, General Manager  
Drinking Water Treatment Units