

## PRODUCT SPECIFICATION

**ITEM CODE: AQF-BB-TRIPLE-2**

**3 STAGE AQF BIG BLUE 10" / 20"  
FILTRATION SYSTEM WITH STAND**

- 1st/2nd STAGE:  
AQF-BB 10" / 20" OPAQUE HOUSING
- 2STAGE FOOT BRACKET
- IN/OUTLET 20": 1" NPT  
IN/OUTLET 10": 1" NPT
- FLOW RATE: 10": 8GPM / 20": 8GPM
- MAX. PRESSURE: 100PSI
- MAX. TEMPERATURE: 120° F (50° C)

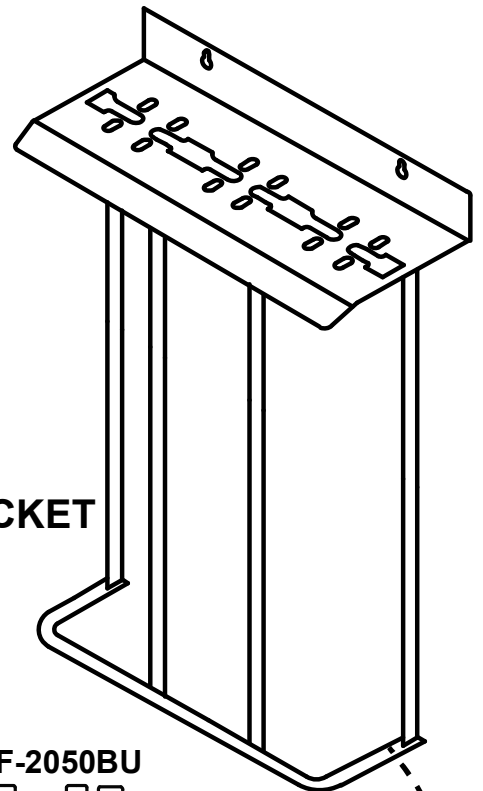

**3 STAGE STAND BRACKET**

**AQF-2050BU**

**AQF-2050BU**

**AQF-2050BU**

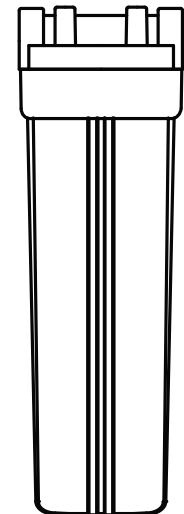

**AQF-1050BU**

**AQF-1050BU**

**AQF-1050BU**

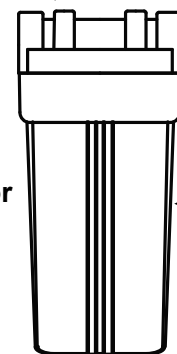
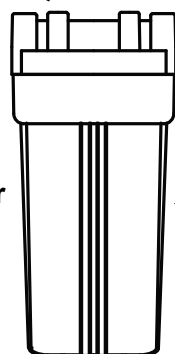
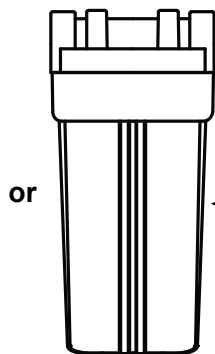

**PPS-2045**  
CARBON BLOCK CARTRIDGE

**PPS-1045**

**APC-2045**  
GRANULAR ACTIVATED CARBON  
CARTRIDGE

**APC-1045**

**PPS-2045**

**PPS-1045**

NSF SEDIMENT CARTRIDGE

**SOURCE  
WATER**

## PRODUCT SPECIFICATION

### MAIN PARTS:

1. AQF-1050 NSF BIG BLUE FILTER HOUSING, OPAQUE, 1" NPT IN/OUTLET  
AQF-2050 NSF BIG BLUE FILTER HOUSING, OPAQUE, 1" NPT IN/OUTLET
2. PPS-1045 NSF Sediment Filter  
PPS-2045 NSF Sediment Filter
3. APC-1045 Carbon Block Filter  
APC-2045 Carbon Block Filter
4. PPS-1045 NSF Sediment Filter  
PPS-2045 NSF Sediment Filter
5. BK-3BB-STAND-10 / 20 Coated Metal Bracket
6. WRS-BB Wrench for AQF big blue housing

## CERTIFICATION

**NSF International**

RECOGNIZES

**Aquapro Industrial Co., Ltd.**

Facility: Nantou County, Taiwan

AS COMPLYING WITH NSF/ANSI 42 AND ALL APPLICABLE REQUIREMENTS.  
PRODUCTS APPEARING IN THE NSF OFFICIAL LISTING ARE  
AUTHORIZED TO BEAR THE NSF MARK.



This certificate is the property of NSF International and must be returned upon request. For the most current and complete information, please access NSF's website ([www.nsf.org](http://www.nsf.org)).

August 10, 2012  
Certificate# C0091259 - 02

A handwritten signature in black ink, appearing to read "Richard Andrew".

Richard Andrew, General Manager  
Drinking Water Treatment Units